



RIDGEWAY Slot Block Barriers



Slot Block Barrier

This is the Slot Block barrier, the patent pending revolutionary site safety barrier exclusively manufactured by Site Supplies Direct. The Slot Block Barrier is the only water filled barrier to hold a standard fencing panel to increase site safety, virtually eliminate potential trip hazards and give added stability to fence panels.

Independently tested by MIRA testing, the Slot Block Barrier will save time and money with the constant re-erection of site fencing and will give you added visibility and corporate identity on 'high profile' sites. Using the Slot Block Barrier contractors dramatically reduce the working footprint by an average of 500mm against a standard fence block.

Features

- > The ONLY water filled barrier made to fit an industry standard 3.5 x 2m mesh panel
- > Corporate colours available
- > Branding and 'mould-in graphics' available
- > 1250 x 150 reflective strips can be added for increased visibility
- > Lights can be added for increased visibility
- > Small footprint for inner-city projects
- > Tested to 57mph by MIRA
- > Rotates 90 degrees
- > 50mm drainage point for easy emptying
- > 75mm Water Fill point
- > 18no Units per Double Pallet (9no 3.5m Complete sets)

100% Recyclable

Dimensions

- > Weighs 14kg when empty
- > Weighs 320kg when full (per 2 units, 1 panel)

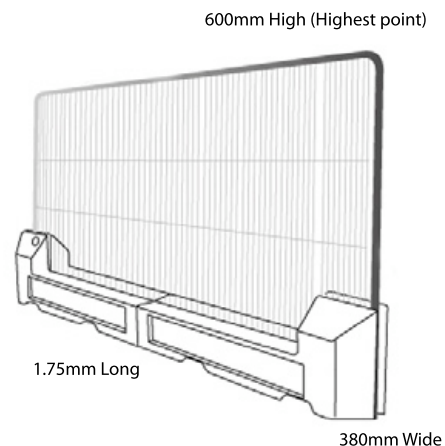

Example of how Slot Block Barrier works



Committed to reducing manual labour costs and Health and Safety incidents?

Then look no further!!



RIDGEWAY

Available for hire and sales

Belfast:
103 Airport Road West
Belfast
Co. Down
BT3 9ED
Tel: +44 (0) 28 454599

Ashbourne:
Unit 1&2 Greene Park
Ratoath Road
Co. Meath
A84 XD98
Tel: +353 (01) 802 7173

Email: info@ridgeway-online.com
Web: www.ridgeway-online.com

